

► Simple, Reliable and Accurate

- Drip-Tight, Positive Seating
- Service Without Removal From Line
- Screwed or flanged ends
- Globe or Angle Pattern
- Every valve factory-tested

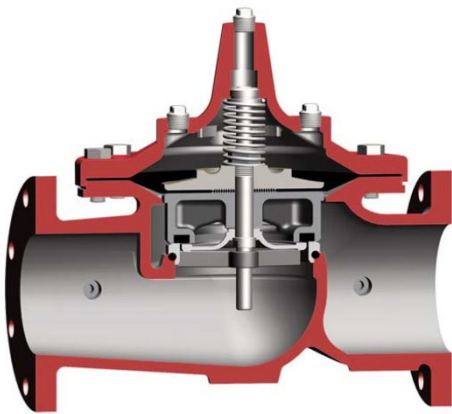

The CLA-VAL Model 100S/2100S Seawater Service Hytrol Valve is a hydraulically operated, diaphragm actuated, globe or angle pattern valve. It consists of three major components: body, diaphragm assembly and cover. The diaphragm assembly is the only moving part.

The body (ductile iron or cast steel) is epoxy coated and contains a removable seat insert. The diaphragm assembly is guided top and bottom by a precision machined stem. It utilizes a non-wicking diaphragm of nylon fabric bonded with synthetic rubber. A resilient synthetic rubber disc retained on three and one half sides by a disc retainer forms a drip-tight seal with the renewable seat when pressure is applied above the diaphragm.

The Model 100S/2100S Seawater Service Hytrol Valve is the basic valve used for seawater applications. It is the valve of choice for system applications requiring deluge, pressure regulation, pressure relief, solenoid operation, rate of flow control, liquid level control or check valve operation. The rugged simplicity of design and packless construction assure a long life of dependable, trouble-free operation. It is available in various materials and in a full range of sizes, with either screwed or flanged ends. Its applications are unlimited.

► CLA-VAL 100S/2100S PRINCIPLE OF OPERATION (ILLUSTRATION TYPE GLOBE)

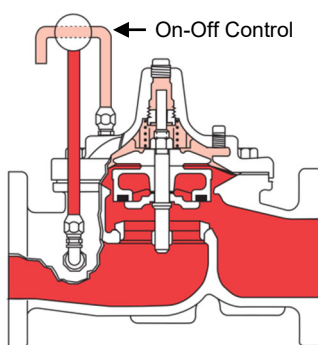

Full Open Operation:

When pressure in the cover chamber is relieved to a zone of lower pressure, the line pressure at the valve inlet opens the valve, allowing full flow.

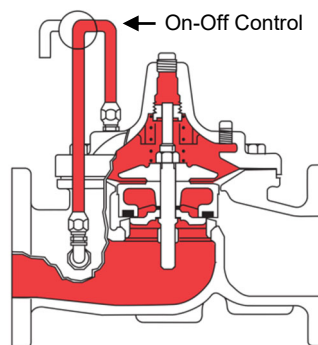

Tight Closing Operation:

When pressure from the valve inlet is applied to the cover chamber, the valve closes drip-tight.

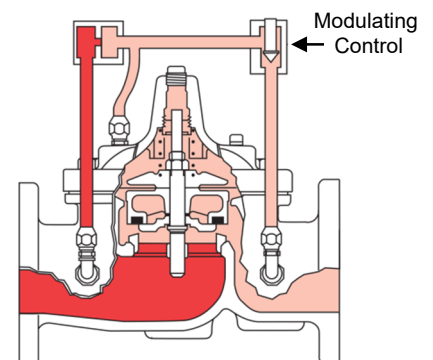

Modulating Action:

The valve holds any intermediate position when operating pressures are equal above and below the diaphragm. A CLA-VAL "Modulating" pilot control will allow the valve to automatically compensate for line pressure changes.

► SPECIFICATIONS

Available Sizes

Pattern	Threaded [Inch]	Flanged [Inch]	Grooved End [Inch]
Globe	1 - 3	1 - 36	1 ½ - 2 - 2 ½ - 3 - 4 - 6 - 8
Angle	1 - 3	2 - 24	2 - 3 - 4

Operating Temp. Range

Fluids
4° to 80°C

Pressure Ratings (Recommended maximum pressure - psi)

Valve body & cover	Pressure Class					
	Material	ANSI Standards*	150 Class	300 Class	300 Class	End ‡ Details
ASTM A536 / EN-GJS-400	Ductile iron	B16.42	250	400	400	400
ASTM A216-WCB	Cast steel	B16.5	285	400	400	400
ASTM B62	Bronze	B16.24	225	400	400	400

Note: *ANSI standards are for flange dimensions only.

‡ Flanged valves are available faced but not drilled.

‡ End details machined to ANSI B2.1 specifications.

Valves for higher pressure are available; consult factory for details.

Materials

Component	Standard material combinations					
	Ductile iron	Cast steel	Bronze	Stainless steel type 316	Ni-Al-Bronze	Super Duplex Stainless Steel
Body & cover						
Available sizes [inch]	1 - 36	1 ¼ - 16	1 ¼ - 16	1 ¼ - 16	1 ¼ - 16	1 ¼ - 16
Disc retainer & diaphragm washer	Cast iron	Cast steel	Bronze	Bronze	Monel	Super Duplex Stainless Steel
Trim: Disc guide, seat & cover bearing	Bronze is standard Stainless steel is optional					
Disc	Buna-N® rubber					
Diaphragm	Nylon reinforced Buna-N® rubber					
Stem, nut & spring	Stainless steel					

For material options not listed, consult factory. CLA-VAL manufactures valves in more than 50 different alloys.

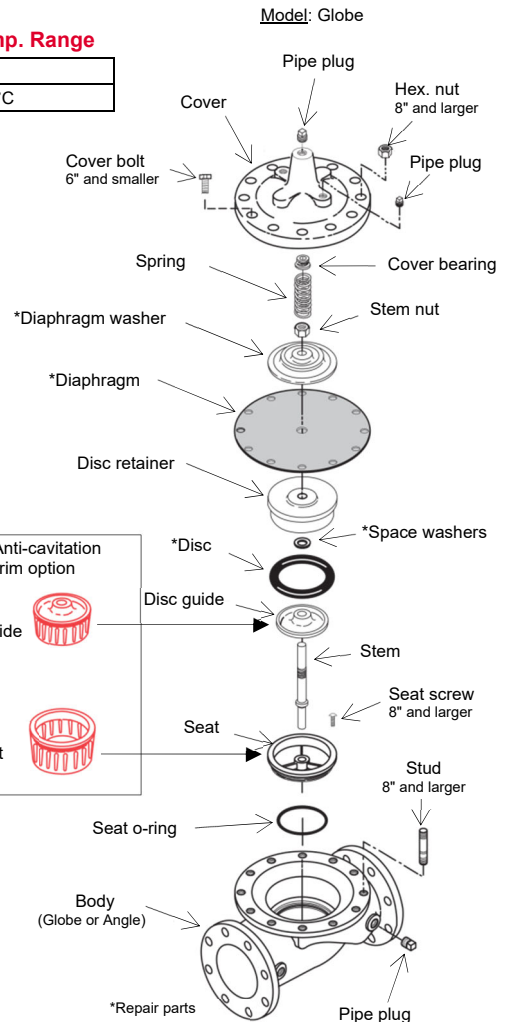

► PURCHASE SPECIFICATIONS

The Model 100S/2100S shall be a hydraulically operated, diaphragm-actuated, globe or angle pattern valve. It shall contain a resilient, synthetic rubber disc, having a rectangular cross-section, contained on three and one-half sides by a disc retainer and disc guide, forming a tight seal against a single removable seat insert. The diaphragm assembly, containing a valve stem, shall be fully guided at both ends by a bearing in the valve cover and an integral bearing in the valve seat. This diaphragm assembly shall be the only moving part and shall form a sealed chamber in the upper portion of the valve, separating operating pressure from line pressure. The diaphragm shall consist of nylon fabric bonded with synthetic rubber and shall not be used as a seating surface. Packing glands or stuffing boxes are not permitted and there shall be no pistons operating the valve or its pilot controls. All necessary repairs shall be possible without removing the valve from the line. All materials shall be compatible with seawater.

For assistance in selecting appropriate valve options or valves manufactured with special design requirements, please contact our Regional Sales Office or Factory.

► WHEN ORDERING, PLEASE SPECIFY

1. Model No. 100S or No. 2100S
2. Valve Size
3. Pattern - Globe or Angle
4. Pressure Class
5. Screwed or Flanged
6. Temperature and fluid to be handled
7. Static and Flowing Line Pressure
8. Body & Trim Material
9. Desired Options
10. When Vertically Installed



CLA-VAL 100S / 2100S

Seawater Service Hytrol Valve

FUNCTIONAL DATA

Valve size		Inches	1	1 ¼	1 ½	2	2 ½	3	4	6	8	10	12	14	16	18	20	24	30	36
		mm	25	32	40	50	65	80	100	150	200	250	300	350	400	450	500	600	750	900
Cv Factor	Globe pattern	Gal./Min. (gpm)	13.3	30	32	54	85	115	200	440	770	1245	1725	2300	3130	3725	5345	7655	10150	14020
		Liters/Sec. (l/s)	3.2	7.2	7.7	13	20	28	48	106	185	299	414	552	752	894	1286	1837	2436	3200
	Angle pattern	Gal./Min. (gpm)	27	27	29	61	101	139	240	541	990	1575	2500*	3060*	4200*	-	-	9950*	-	-
		Liters/Sec. (l/s)	6.5	6.5	7	15	24	33	58	130	238	378	600	734	1008	-	-	2388	-	-
Equivalent length of pipe (L)	Globe pattern	Feet (ft.)	23	19	37	51	53	85	116	211	291	347	467	422	503	612	595	628	1181	2285
		Meters (m)	7.1	5.7	12	15.5	16	26	35	64	89	106	142	129	154	187	181	192	552	569
	Angle pattern	Feet (ft.)	28	28	46	40	37	58	80	139	176	217	222*	238*	247*	-	-	372*	-	-
		Meters (m)	8.7	8.7	14	12	11	18	25	43	54	66	68	73	75	-	-	113	-	-
K Factor	Globe pattern		6.1	3.6	5.9	5.6	4.6	6.0	5.9	6.2	6.1	5.8	6.1	5.0	5.2	5.2	4.6	4.0	5.3	7.8
	Angle pattern		4.4	4.4	7.1	4.4	3.3	4.1	4.1	4.1	3.7	3.6	2.9	2.8	2.6	-	-	2.4	-	-
Liquid displaced from cover chamber when valve opens	Fl. Oz		-	-	-	-	-	-	-	-	-	-	-	-	-	-	-	-	-	-
	U.S. Gal.		0.02	0.02	0.02	0.03	0.04	0.08	0.17	0.53	1.26	2.51	4.0	6.5	9.6	11	12	29	42	90
	ml		20.7	75.7	75.7	121	163	303	643	-	-	-	-	-	-	-	-	-	-	-
	Liters		-	-	-	-	-	-	-	2.0	4.8	9.5	15.1	24.6	36.2	41.6	45.4	109.8	197	340

*Estimated

Cv Factor:

Formulas for computing Cv Factor, Flow (Q) and Pressure Drop (ΔP):

$$C_v = \frac{Q}{\sqrt{\Delta P}} \quad Q = C_v \sqrt{\Delta P} \quad \Delta P = \left(\frac{Q}{C_v}\right)^2$$

K Factor (Resistance coefficient)

The value of K is calculated from the formula:
(U.S. system units)

$$K = \frac{894d^4}{C_v^2}$$

Equivalent length of pipe

Equivalent lengths of pipe (L) are determined from the formula:
(U.S. system units)

$$L = \frac{K d}{12 f}$$

Fluid Velocity

Fluid velocity can be calculated from the following formula:
(U.S. system units)

$$V = \frac{0.4085 Q}{d^2}$$

Where:

C_v = U.S. (gpm) @ 1 psi differential at 60°F water

or

C_v = (l/s) @ 1 bar (14.5 PSIG) differential at 15°C water

d = Inside pipe diameter of schedule 40 steel pipe (inches)

f = Friction factor for clean, new schedule 40 pipe (dimensionless) (from Cameron hydraulic data, 18th edition, P 3-119)

K = Resistance coefficient (calculated)

L = Equivalent length of pipe (feet)

Q = Flow rate in U.S. (gpm) or (l/s)

V = Fluid velocity (feet per second) or (meters per second)

ΔP = Pressure drop in (psi) or (bar)

MODEL 100S/2100S FLOW CHART (BASED ON NORMAL FLOW THROUGH A WIDE OPEN VALVE)

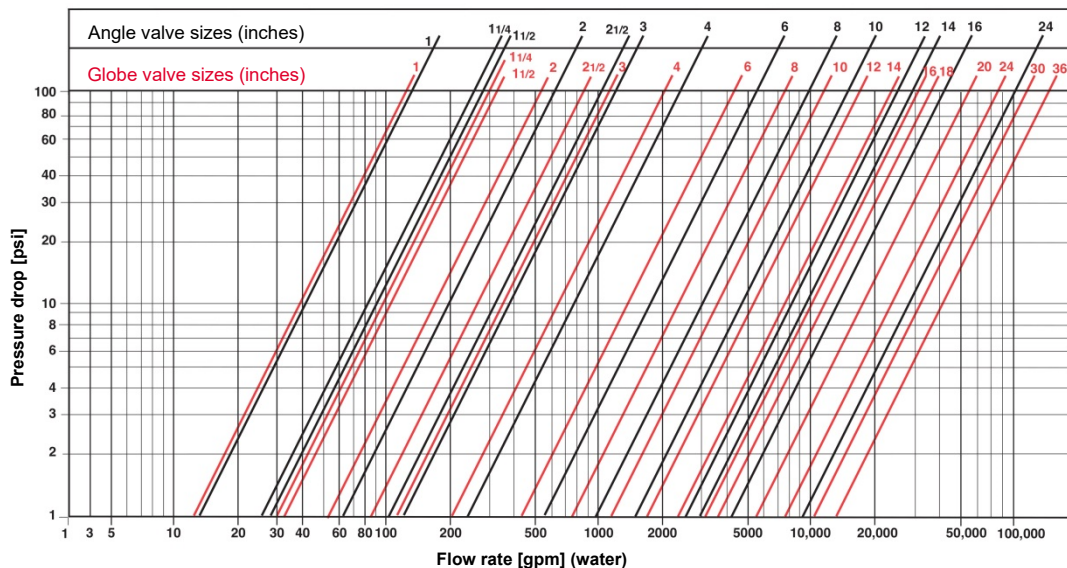

► DIMENSIONS

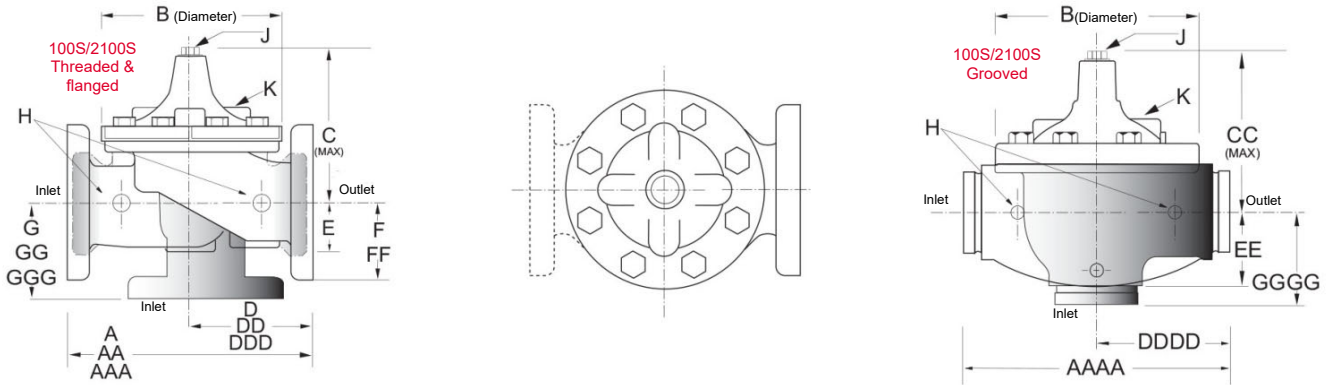

Valve size (mm)	25	32	40	50	65	80	100	150	200	250	300	350	400	450	500	600	750	900
A Threaded	184	184	184	238	279	318	-	-	-	-	-	-	-	-	-	-	-	-
AA 150 ANSI	-	-	216	238	279	305	381	508	645	756	864	991	1051	1168	1321	1562	1600	1930
AAA 300 ANSI	-	-	229	254	295	337	397	533	670	790	902	1029	1105	1210	1362	1606	1638	1930
AAAA Grooved end	-	-	216	228	279	318	381	508	645	-	-	-	-	-	-	-	-	-
B Dia.	143	143	143	168	203	232	292	400	508	600	711	832	902	1054	1143	1350	1422	1676
C Max.	140	140	140	165	192	208	270	340	406	435	530	614	635	992	1064	1116	1387	1562
CC Max. Grooved end	-	120	120	146	175	184	236	308	371	-	-	-	-	-	-	-	-	-
D Threaded	83	83	83	121	140	159	-	-	-	-	-	-	-	-	-	-	-	-
DD 150 ANSI	-	-	102	121	140	152	191	254	322	378	432	495	528	-	-	781	-	-
DDD 300 ANSI	-	-	108	127	149	162	200	267	337	395	451	514	549	-	-	803	-	-
DDDD Grooved end	-	-	-	121	-	152	191	-	-	-	-	-	-	-	-	-	-	-
E	29	29	29	38	43	52	81	110	135	235	273	321	394	329	381	451	541	624
EE Grooved end	-	-	52	64	73	79	108	152	192	-	-	-	-	-	-	-	-	-
F 150 ANSI	-	-	64	76	89	95	114	140	171	203	241	267	298	381	419	489	572	650
FF 300 ANSI	-	-	78	83	95	105	127	159	191	222	260	292	324	381	419	489	610	650
G Threaded	48	48	48	83	102	114	-	-	-	-	-	-	-	-	-	-	-	-
GG 150 ANSI	-	-	102	83	102	102	127	152	203	219	349	378	399	-	-	560	-	-
GGG 300 ANSI	-	-	102	89	110	111	135	165	216	236	368	397	419	-	-	582	-	-
GGGG Grooved end	-	-	-	83	-	108	127	-	-	-	-	-	-	-	-	-	-	-
H NPT body tapping	3/8"	3/8"	3/8"	3/8"	1/2"	1/2"	3/4"	3/4"	1"	1"	1"	1"	1"	1"	1"	1"	2"	2"
J NPT cover center plug	1/4"	1/4"	1/4"	1/2"	1/2"	1/2"	3/4"	3/4"	1"	1"	1 1/4"	1 1/2"	2"	1 1/2"	1 1/2"	1 1/2"	2"	2"
K NPT cover tapping	3/8"	3/8"	3/8"	3/8"	1/2"	1/2"	3/4"	3/4"	1"	1"	1"	1"	1"	1"	1"	1"	2"	2"
Valve stem internal thread UNF	10-32	10-32	10-32	10-32	10-32	1/4-28	1/4-28	3/8-24	3/8-24	3/8-24	3/8-24	3/8-24	3/8-24	1/2-20	3/4-16	3/4-16	3/4-16	3/4-16
Stem travel	10	10	10	15	18	20	28	43	58	71	86	102	114	130	143	171	190	216
Approx. ship Wt. Kg	7	7	7	16	23	32	64	129	227	354	528	726	1027	1353	1769	2812	3494	5316

CLA-VAL control valves operate with maximum efficiency when mounted in horizontal piping with the main valve cover UP, however, other positions are acceptable. Due to component size and weight of 8 inch and larger valves, installation with cover UP is advisable. We recommend isolation valves be installed on inlet and outlet for maintenance. Adequate space above and around the valve for service personnel should be considered essential. A regular maintenance program should be established based on the specific application data. However, we recommend a thorough inspection be done at least once a year. Consult factory for specific recommendations.